



Instructions for the safe use of: Web Lashings

The information in this leaflet should be passed to the user of the equipment

This document is issued in accordance with the requirements of Section 6 of the Health and Safety at Work etc Act 1974, amended March 1988.

This information is of a general nature only covering the main points for the safe use of Web Lashings made from man-made fibre. It may be necessary to supplement this information for specific applications. See also the general guidance on load restraint, given overleaf.

ALWAYS:

- Inspect web lashings before use.
- Calculate the lashing force(s) required for the chosen method of load restraint.
- Select the capacity and number of web lashings to provide at least the calculated lashing force(s)
- Ensure the lashing points on the vehicle and/or load are of adequate strength.
- Position the web lashing so that the load is uniformly spread over its width and protect the web lashing from small radii, especially sharp edges.
- Ensure the web lashings are correctly tensioned.
- Exercise care when releasing web lashings in case the load has become unstable since the lashings were applied.

NEVER:

- Use web lashings to lift a load.
- Knot or tie web lashings.
- Overload web lashings.
- Use web lashings over a sharp edge without edge protection.
- Expose web lashings to direct heat or flames.
- Expose web lashings to chemicals without consulting the supplier.
- Use web lashings which are cut, have loose or damaged stitching, a damaged tensioner or damaged terminal fittings.

Selecting the Correct Web Lashing

The standard for web lashings is BS EN 12195-2: 2001.

Web lashings are available in a range of capacities and lengths and in various configurations. Some are general purpose. Others are intended for specific applications such as securing cars by their wheels.

Selection should start with an assessment of the forces acting on the load. The lashing force(s) required should be calculated in accordance with BS EN 12195-1: 2010.

Next check whether the lashing points on the vehicle and/or load are of adequate strength. If necessary apply a greater number of lashings to spread the force across more lashing points.

Web lashings are marked with their lashing capacity (LC), expressed in daN (deca Newton = 10 Newtons) This is a force approximately equivalent to a weight of 1kg.

Using Web Lashings Safely

Ensure that the tensioner is free to align and not bent over an edge. Ensure that the webbing is not twisted or knotted and that the terminal fittings engage correctly with the lashing points.

Ensure that the webbing is loaded evenly across its width and protected from sharp and small radius edges by suitable sleeves or edge protectors.

Checking the tension after travelling a short distance is recommended.

Ensure that the webbing is protected against sources of friction, abrasion and heat.

In-service Inspection and Storage

Web lashings can easily be damaged by tensioning the webbing across small radius edges or loading the edge of the webbing instead of ensuring the load is spread over its full width. Avoid this by correct placement of the web lashing and the use of protective sleeves and edge protection. However damage may occur accidentally as a result of the load moving in transit hence the need to inspect before each use.

Web lashings may accidentally be exposed to chemicals. Most are manufactured from polyester which is resistant to moderate strength acids but is damaged by alkalis. Weak chemical solutions will become increasingly stronger by evaporation. If appropriate, the webbing may be cleaned with clear water and allowed to dry naturally. Never force dry web lashings.

Web lashings should be inspected for obvious signs of damage before each use. Do not use the web lashing if any of the following defects are found: illegible markings; damaged, chaffed or cut webbing; damaged or loose stitching; heat damage; burns; chemical damage; solar degradation; damaged or deformed end fittings.

Web lashings will deteriorate gradually over time due to normal wear. The LEEA recommends that they should be inspected by a competent person at least every 6 months and a record made of the result.

Web lashings should only be repaired by someone competent to do so.

For long term storage the storage area should be dry, clean, free of any contaminants and shaded from direct sunlight.

© Lifting Equipment Engineers Association 2012 SI No. 23.0

Further information is given in:

BS EN 12195-1: 2010 Load restraining on road vehicles – Safety – Part 1: Calculation of securing forces

BS EN 12195-2: 2001 Load restraining on road vehicles – Safety – Part 2: Web lashing made from man-made fibres
European Best Practice Guidelines on Cargo Securing for Road Transport

Department for Transport code of practice – Safety of Loads on Vehicles.

LIFTING EQUIPMENT ENGINEERS ASSOCIATION



3 Osprey Court, Kingfisher Way,
Hinchingsbrooke Business Park, Huntingdon,
Cambridgeshire. PE29 6FN United Kingdom
Tel: + 44 (0) 1480 432801
Fax: + 44 (0) 1480 436314
E-mail: mail@leea.co.uk
Website: www.leeaaint.com



**Global Lifting
Services Nigeria**

PLOT 301 Ordinance Road, Trans Amadi
Industrial Layout Port-Harcourt, Nigeria
P.O.BOX 6212 Trans Amadi.
Tel: +234(0)8169911111
Email: enquiries@global-lifting.com
Website: www.global-lifting.com

General Guidance on Load Restraint

This information is of a general nature only covering the main principles of load restraint.

Terminology

Load restraint is a general term covering all three methods of securing loads to vehicles. Without restraint a load is very likely to slide or topple in transit. The three methods are:

Blocking

Blocking is a securing method where the load lies against fixed structures or fixtures on the vehicle such as headboards, sideboards, stanchions or bracing which prevents the load from sliding or toppling.

Lashing

Lashing is a securing method which uses flexible lashing equipment to tie the load to the vehicle. There are two main types of lashing, frictional lashing (also known as top-over' lashing) and direct lashing.

Frictional lashing forces the load onto the bed of the vehicle so as to increase the friction between the load and the vehicle bed. See figure 1.

Direct lashing connects a load bearing attachment point on the load to a lashing point on the vehicle. See figure 2.

Many lashing systems are a combination of direct and frictional lashing. Lashing can be used in conjunction with blocking.

Locking

Locking is a securing method where the load is secured to the vehicle by mechanical devices such as the twist locks which secure freight containers.

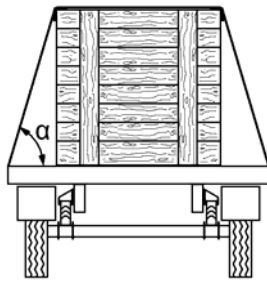

Figure 1
Example of frictional lashing

Figure 1 illustrates a wooden crate secured by a friction lashing. It is the vertical component of the tension in the lashing which forces the crate onto the bed of the vehicle. The maximum friction is obtained when $\alpha = 90^\circ$. When α reduces, the friction reduces. For example, when α is 30° , the effect is halved. The amount of friction also depends upon the friction factors of the materials the load and the bed are made from. (See Annex B of BS EN 12195-1 for a table of friction factors.) It can be enhanced by using a friction mat between the load and the bed.

Figure 2 illustrates a dumper truck secured by direct lashing. With direct lashing it is the horizontal component of the tension in the lashing which provides the majority of the longitudinal and transverse restraint. This horizontal component of the tension increases as α decreases.

Whilst the vertical component does increase the friction, the contribution of the friction to the overall restraint is relatively small. In plan view, the longitudinal lashing angle β_x controls the balance between the longitudinal and transverse restraint. For a given lashing capacity and vertical lashing angle α , as β_x increases, the longitudinal restraint decreases and the transverse restraint increases.

Direct lashing can only be used when both the load and the bed have lashing points compatible with the required strength of the lashing.

Other methods of lashing are loop lashing, spring lashing and round turn lashing. These are often used in conjunction with blocking. The European Best Practice Guidelines illustrates all these methods and explains them in more detail.

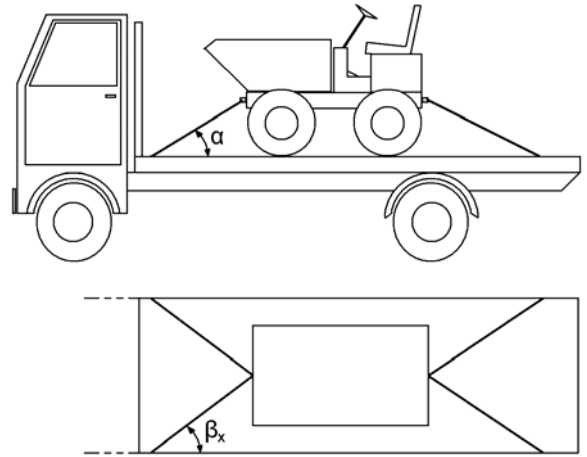

Figure 2
Example of direct lashing

Forces acting on the load

Loads on road vehicles are subjected to the forces generated due to the vehicle accelerating, braking and cornering.

EN 12195-1 specifies how the lashing forces should be calculated based on the possible acceleration of the load. The acceleration is expressed as a coefficient which, in effect, is the proportion of the weight of the load which the lashing must restrain in a particular direction.

Figure 3 illustrates the forces which can arise from the acceleration, braking and cornering of an HGV under normal driving conditions. For example, under braking the load can push forward with a force equivalent to 0.8 of the weight of the load.

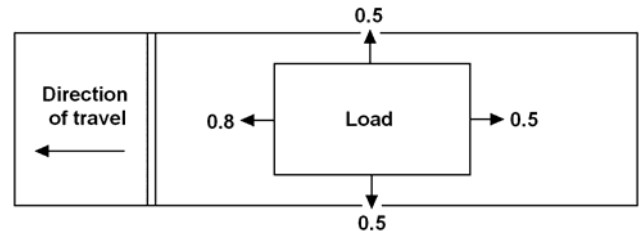

Figure 3
Forces acting on the load

As well as trying to make the load slide, these forces may try to topple the load. Additional restraint may therefore be required to prevent the load from toppling.

Lighter vehicles generally can accelerate, brake and corner more sharply than those classed as an HGV. Therefore higher forces may act on the load if the gross vehicle weight is less than 3,500kg. Higher forces may also act on the load if the vehicle is transported by rail or sea.

Other considerations

The standards and guidance assume that the bed of the vehicle is equipped with suitable lashing points. Unfortunately this is not always true. It may be possible to achieve adequate restraint by using a greater number of lashings thus sharing the load across more lashing points. However it must be shared equally taking account of possible movement in transit.

Lashing equipment used without protection over the edges of a load can result in the load damaging the lashing equipment. The degree of risk varies with the type of lashing equipment. See the specific guidance overleaf.

Periodically checking the lashing equipment for security and tension during a journey is recommended.

Fixing and releasing load lashings often involves working at height or alongside the vehicle at the roadside, both of which can be hazardous. Users should consider the risks involved and address them when planning the method of load restraint.